

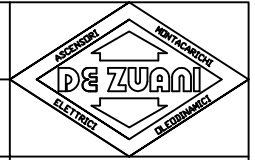

PEA - i

220V MONOFASE



Fermate max 5
Corsa max 12,40 m

PIATTAFORMA ELEVATRICE AUTOMATICA
DIRETTIVA EUROPEA 06/42/CE

Velocità m/s
0,15

PIANTA VANO

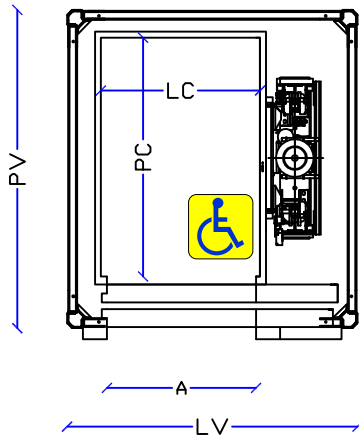

PIANTA VANO d.i. Doppio ingresso

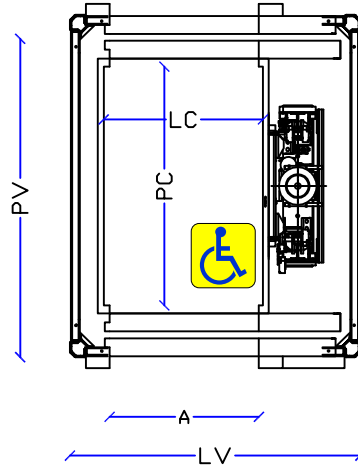

SEZIONE VANO

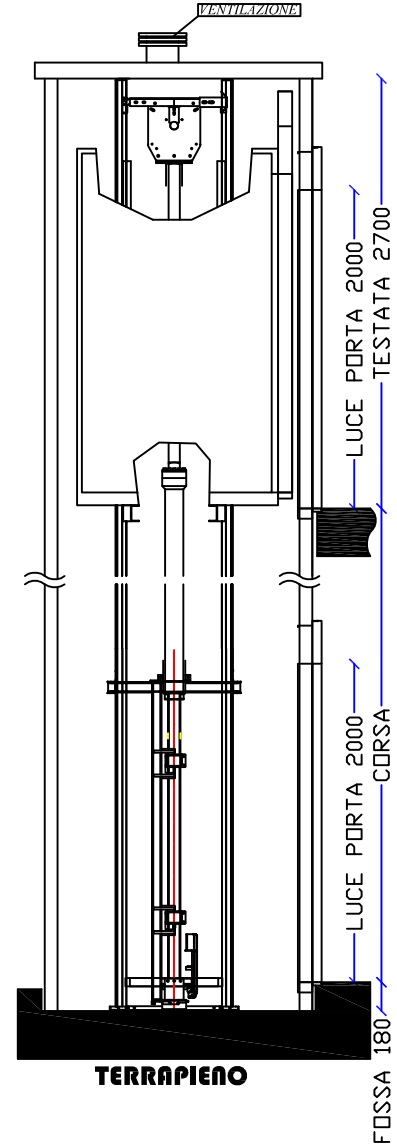

TIPO	PORTATA Kg	PERSONE	LC (mm)	PC (mm)	A (mm)	LV (mm)	PV (mm)
PEA 0-i	250	3	800	1200	750	1460	1600
					800	1560	1550
PEA 0-i d.i.	250	3	800	1200	750	1460	1710
					800	1560	1630
PEA 1-i	250	3	800	1250	750	1460	1640
					800	1550	1600
PEA 1-i d.i.	250	3	800	1250	750	1460	1760
					800	1550	1680
PEA 2-i	325	4	1000	1300	800	1550	1700
					900	1700	1700
PEA 2-i d.i.	325	4	1000	1300	800	1550	1810
					900	1700	1810
PEA 3-i	385	5	1100	1400	800	1650	1800
					900	1700	1800
PEA 3-i d.i.	385	5	1100	1400	800	1650	1910
					900	1700	1910

Per dimensionamenti diversi da quelli indicati contattare l'azienda

CARICHI SUL FONDO FOSSA

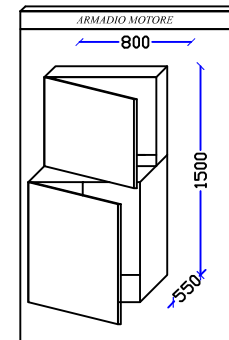
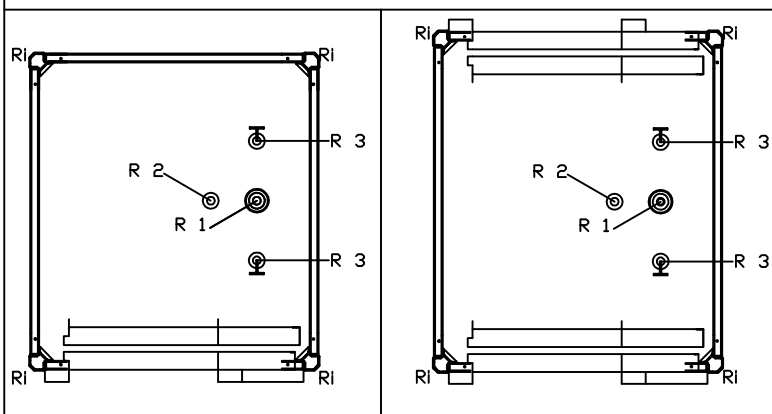

TIPO	Fx (daN)	Fy (daN)	R1 (daN)	R2 (daN)	R3 (daN)
PEA 0	210	65	2750	3140	785
PEA 1	210	65	2750	3140	785
PEA 2	270	75	3200	3700	920
PEA 3	310	85	3945	4740	1180

SPINTE DINAMICHE
SULLE GUIDE
(passo 1500 mm)



QUESTO DISEGNO E' DI ESCLUSIVA PROPRIETA'
DELLA ASCENSORI DE ZUANI DIVIETO DI
RIPRODUZIONE O DIVULGAZIONE SENZA
PREVENTIVA AUTORIZZAZIONE
Art. 2.99 Legge 22 - 1847

Revisione 1.1
del gen. 2011
Approvaz. G.P.
Pagina
1
di 1